



KONICA MINOLTA

# MULTI GLOSS 268 (20°, 60°, 85°) UNI GLOSS 60 (60°)

Makes its debut with more multifunction to achieve the effective gloss measurement.



• It has data compatibility with the previous MULTI GLOSS 268 / UNI GLOSS 60, and improves repeatability and reproducibility.

• Approx. 10,000 measurements are available with one AA(R6) size alkaline battery.

**Large screen size and easily viewable liquid crystal display.**

**Easy operation with mode scroll wheel.**

By operating the mode scroll wheel in accordance with easy-to-understand menu items, you can set a wide array of functions easily.



You can select Mode, Geometry selection, Difference, and Calibration from the Main Menu screen.

**A wide array of display modes (corresponding to six languages)**

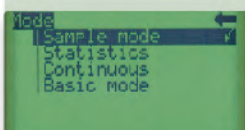

You can measure by selecting Basic mode, Continuous, Statistics from the Mode screen.

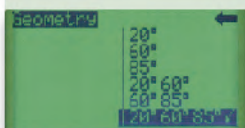

You can select the measurement angle from the Geometry selection screen and display two angles or three angles at the same time.

(MULTI GLOSS 268)

**Wide measurement range that can be measured from plastic to metal surface with a high gloss finish : 0.0~2,000 GU (in the case of 20°)**

**The gloss difference measurement of the standard/sample and the PASS/FAIL evaluation.**

You can make a pass/fail evaluation by setting the limit value. You can enter the sample name and the standard value name in the measurement result.

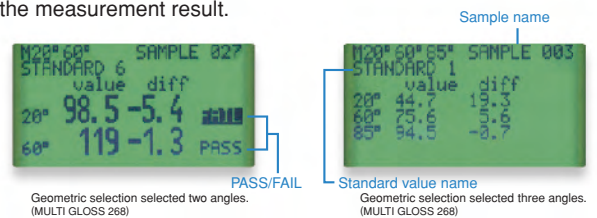

Geometric selection selected two angles. (MULTI GLOSS 268)

Geometric selection selected three angles. (MULTI GLOSS 268)

**Autodiagnosis function of calibration**

This means a little frequency of calibration and long-term stability. In addition, if the calibration is required, the message will be displayed.

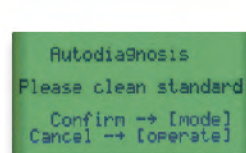

Calibrating standard



Protective holder

The essentials of imaging

With dedicated Data transfer software (gloss-link), the data management such as data transfer to Excel®\* is easy.

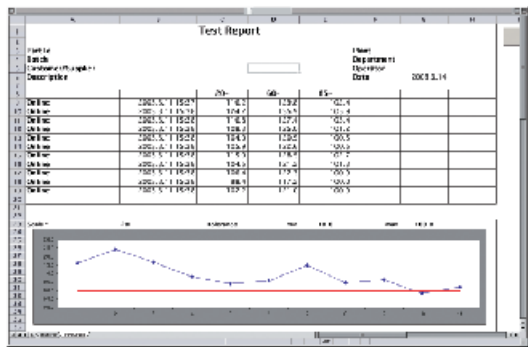

OS Windows®98/2000/Me/XP, Windows NT®4.0

\* Microsoft Excel® 97 or higher.  
Windows®, Windows NT® and Excel® is a trademark or registered trademark of Microsoft Corporation of America or its subsidiaries.

## Dimensions

Units : mm

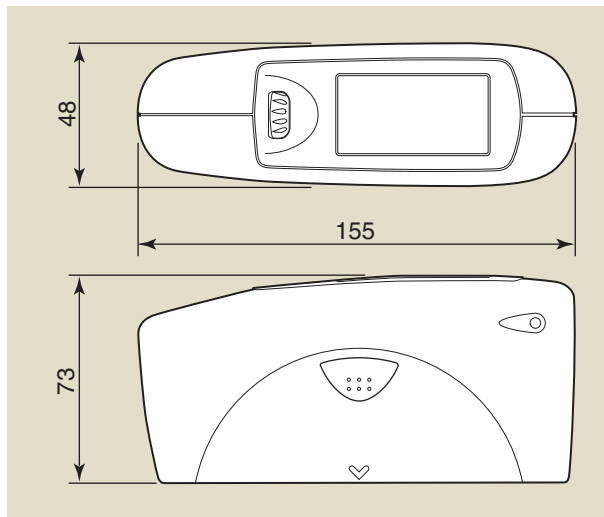

## Specifications

Model	MULTI GLOSS 268	UNI GLOSS 60
Measurement geometry	20°, 60°, 85°	60°
Size of measurement spot	20° : 10 X 10 mm 60° : 9 X 15 mm 85° : 5 X 38 mm	60° : 9 X 15 mm
Standard compliance	ISO 2813, ISO 7668, ASTM D 523, ASTM D 2457, DIN 67 530, JIS Z 8741, BS 3900, BS 6161(Part 12)	
Measurement range	20° : 0.0~2,000 GU 60° : 0.0~1,000 GU 85° : 0.0~160 GU	60° : 0.0~1,000 GU
Resolution	0.0~99.9 GU : 0.1 GU 100~2,000 GU : 1 GU	
Repeatability	0.0~99.9 GU : 0.2 GU 100~2,000 GU : 0.2% of reading	
Inter Instrument agreement	0.0~99.9 GU : 0.5 GU 100~2,000 GU : 0.5% of reading	
Memory	999 measurements with date and time	
Difference measurement	Memory for 50 standard	
Battery performance	Approx. 10,000 measurements (when using 1.5 V AA(R6)size alkaline battery)	
Measurement time	0.5 seconds (each measurement)	
Power OFF	Auto : 10~99 seconds select	
Languages	English, Spanish, German, French, Italian, Japanese	
Measurement mode	Normal mode (Sample mode, Statistics, Continuous, Basic mode), Difference mode	
Interface	RS-232C format	
Operating temperature /humidity range	15 to 40°C relative humidity 85% or less (at 35°C) with no condensation	
Storage temperature /humidity range	-10 to 60°C relative humidity 85% or less (at 35°C) with no condensation	
Power supply	1.5 V AA(R6)size alkaline battery	
Dimensions	155(W) X 73(H) X 48(D) mm	
Weight	400 g	

## Accessories

Model	MULTI GLOSS 268	UNI GLOSS 60
Standard accessories	Calibration holder TRI (High gloss tile) PC-cable Carrying case Data transfer software (gloss-link) 1.5 V AA(R6)size alkaline battery	Calibration holder 60° (High gloss tile)
Optional accessories	Checking standard TRI (3 semi gloss tiles 20, 60, 85°) Checking standard mirror (3 tiles 20, 60, 85°) USB-adapter AC adapter	Checking standard 60° (High and semi gloss tile)

Note : The specifications described in this document are subject to change without notice.

MULTI GLOSS 268 / UNI GLOSS 60 conforms with international specifications ASTM D 523, DIN 67 530, ISO 2813.

ASTM

DIN

ISO



Certificate No : YKA 0937154  
Registration Date : March 3, 1995

Certificate No : JQA-E-80027  
Registration Date : March 12, 1997

### SAFETY PRECAUTIONS



For correct use and for your safety, be sure to read the instruction manual before using the instrument.

- Always connect the instrument to the specified power supply voltage. Improper connection may cause a fire or electric shock.
- Be sure to use the specified batteries. Using improper batteries may cause a fire or electric shock.

**KONICA MINOLTA SENSING, INC.** Osaka, Japan  
**Konica Minolta Sensing Americas, Inc** New Jersey, U.S.A.  
**Konica Minolta Sensing Europe B.V.** European Headquarter /BENELUX

German Office (International)  
German Office (Germany)  
French Office  
UK Office  
Italian Office  
Swiss Office  
Nordic Office  
Austrian Office  
Polish Office

**Konica Minolta (CHINA) Investment Ltd.** SE Sales Division  
SE Beijing Office  
SE Guangzhou Office

**Konica Minolta Sensing Singapore Pte Ltd.**  
**KONICA MINOLTA SENSING, INC.** Seoul Office

**Phone** : 888-473-2656(in USA), 201-236-4300(outside USA)

Nieuwegein, Netherland  
Langenhagen, Germany  
München, Germany  
Roissy CDG, France  
Milton Keynes, United Kingdom  
Milan, Italy  
Dietikon, Switzerland  
Västra Frölunda, Sweden  
Wien, Austria  
Warszawa, Poland

Shanghai, China  
Beijing, China  
Guangzhou, China  
Singapore  
Seoul, Korea

**Phone** : +31(0)30 248-1193

**Phone** : +49(0)511 7404-862  
**Phone** : +49(0)89 630267-9700  
**Phone** : +33(0)1 493-82519  
**Phone** : +44(0)1908 540-622  
**Phone** : +39(0)23 90111  
**Phone** : +41(0)43 322-9800  
**Phone** : +46(0)31 7099464  
**Phone** : +43(0)1 87882-430  
**Phone** : +48(0)22 56033-00

**Phone** : +86-021-5489 0202  
**Phone** : +86-010-8522 1551  
**Phone** : +86-020-3826 4220  
**Phone** : +65 6563-5533  
**Phone** : +82(0)2-523-9726

**Fax** : 201-785-2480

**Fax** : +31(0)30 248-1280  
**Fax** : +49(0)511 7404-807  
**Fax** : +49(0)89 630267-9799  
**Fax** : +33(0)1 493-84771  
**Fax** : +44(0)1908 540-629  
**Fax** : +39(0)23 9011219  
**Fax** : +41(0)43 322-9809  
**Fax** : +46(0)31 474945  
**Fax** : +43(0)1 87882-431  
**Fax** : +48(0)22 56033-01

**Fax** : +86-021-5489 0005  
**Fax** : +86-010-8522 1241  
**Fax** : +86-020-3826 4223  
**Fax** : +65 6560-9722  
**Fax** : +82(0)2-523-9729

Addresses and telephone/fax numbers are subject to change without notice. For the latest contact information, please refer to the KONICA MINOLTA SENSING Worldwide Offices web page (link below).

<http://konicaminolta.com/about/se/contact.html>